

COMMERCIAL WALL MOUNT AUTOMATIC MOTION SENSOR FAUCET SPECIFICATIONS

Technical Information



- 0.5 gpm (1.9 LPM) maximum flow rate.
- Vandal-resistant aerator.
- 9" (229 mm) spout reach.

Flow rate : 0.5 gal/min (1.9 L/min)

Pressure : 60 psi (4.1 bar)

Size

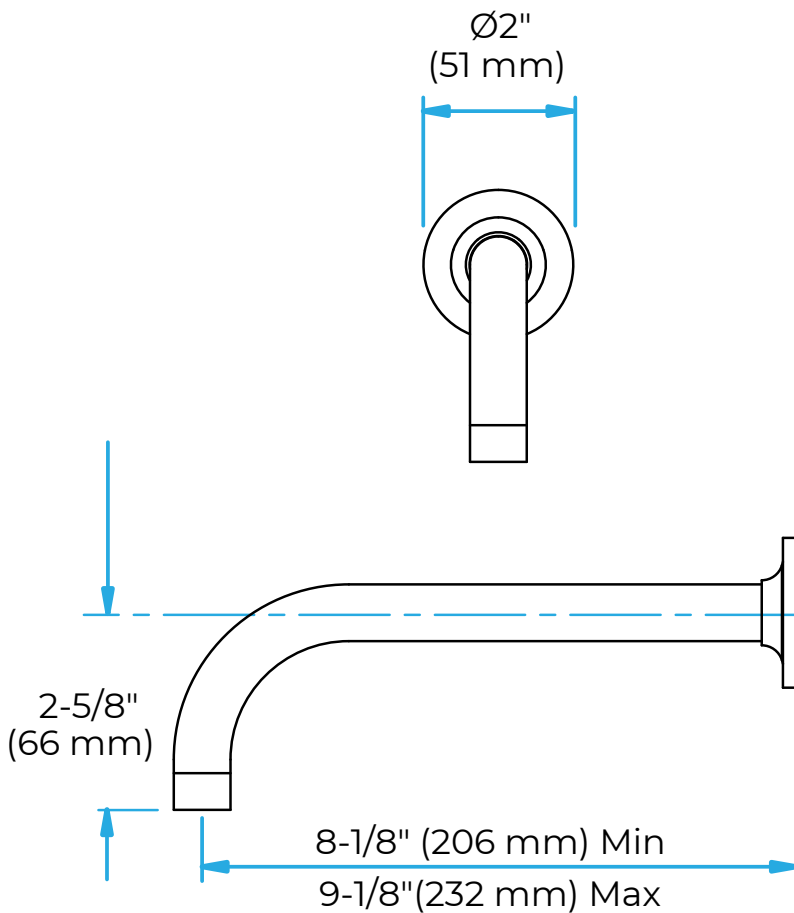

Overview

